

**OPERATING  
INSTRUCTIONS**  
FOR ALL V-E MODELS



**RAPIDPRINT**

DIVISION OF

**BIDWELL Industrial Group, Inc.**

2055 SOUTH MAIN STREET  
MIDDLETOWN, CT. 06457

Your RAPIDPRINT machine features an electronic stamping mechanism. This design ensures consistently clear imprints. Electronic components offer superior reliability and performance.

## **GENERAL INSTRUCTIONS**

Check the current, voltage, and cycles as given on name plate and be certain that those specifications conform with the electrical power you intend using. Make a record of the serial number of this machine and the number given on the key for reference.

When ordering parts or making any inquiry be sure to give the serial number and the model designation, i.e. #271236; VAR-LH-E.

### **NOTE!**

Generally it is wise to disconnect the machine from the wall receptacle whenever the top casting of the machine is going to be opened - (for wheel setting, changing ribbon, etc.) Always remember to reset the wheels to the correct time after such periods.

# INDEX

	<b>Page No.</b>
Diagram - Wheel Setting .....	1
Instructions for Setting Printing Wheels .....	2
Instructions for Setting Analog Clock.....	3
Instructions for Setting Digital Clock .....	4
How to Obtain Impressions .....	6
Diagram - Ribbon Installation .....	7
Instructions for Removing and Installing Ribbon .....	8
Maintenance Hints .....	9

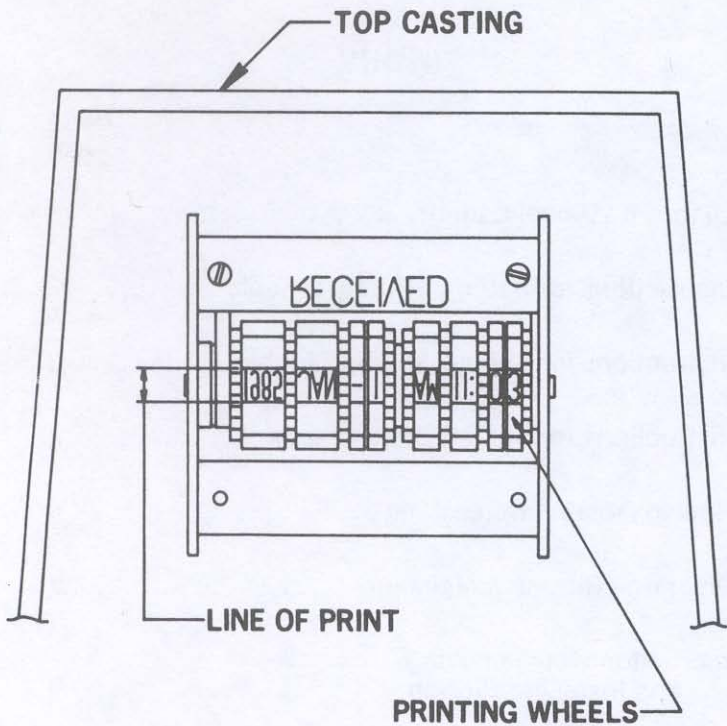

**DIAGRAM "A"**

## INSTRUCTIONS FOR SETTING PRINTING WHEELS

**NOTE:** Always unplug machine before opening. With machine facing operator unlock and lift up top casting.

To set wheels to proper position, turn wheels downward with a pencil or wooden stylus until they are in line. See diagram A.

The use of a metal stylus can damage the printing characters.

**TIME STAMPS** - The wheels operate automatically to the end of the month. Reset the date and month wheels at the first of each month and the year wheel on the first of each year.

**DATE STAMPS** - (without time) The wheels must be reset daily.

**NUMBERING MACHINES** - Only the first six wheels operates automatically. Additional wheels must be hand set. If a date section is included the date wheels must be reset daily.

## ANALOG CLOCK

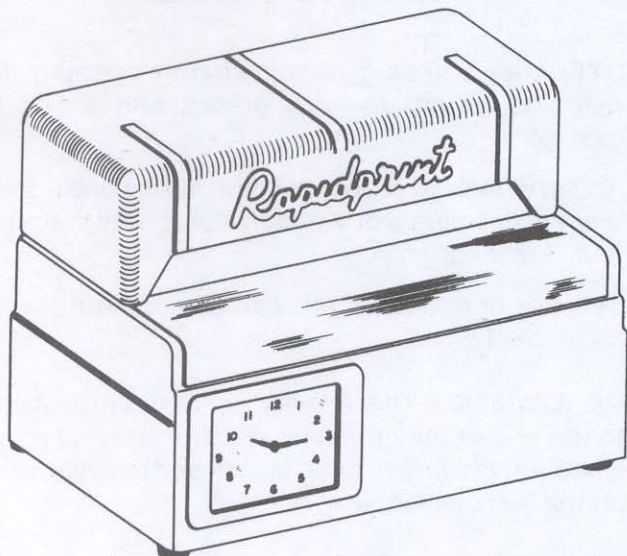

### INSTRUCTION FOR SETTING ANALOG CLOCK

Set the hands to the proper time by using the setting wheel which protrudes from the bottom of the clock base.

## DIGITAL CLOCK

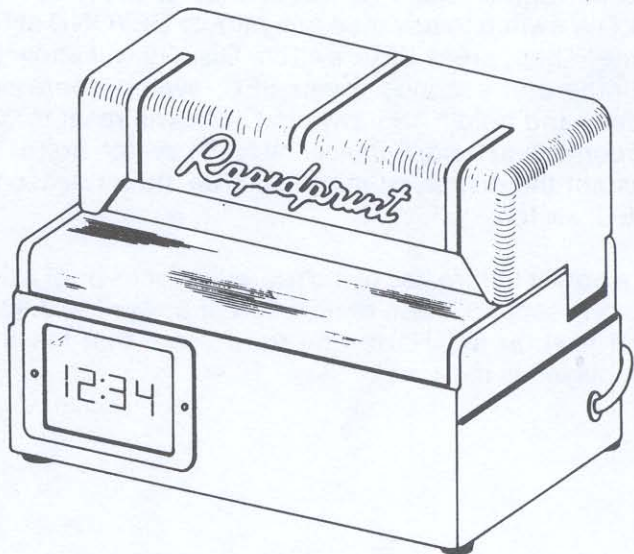

### INSTRUCTIONS FOR SETTING DIGITAL CLOCK

1. Press FAST switch until correct hour is displayed.
2. Press SLOW switch to advance to correct minute setting.

*(Continued from Page 4)*

To set digital clock to the precise second, use the SLOW switch to advance one minute BEYOND actual time. Then, press SEC. switch. Display will show the minute and seconds. Keep SEC. switch depressed. Press and hold FAST switch. Clock will reset to "00" seconds and hold. Release the FAST switch first at the instant the displayed minute is true, then release the SEC. switch.

If a power failure has occurred, even for as brief a time as one second, upon restoration of power the display will flash at a 1 Hertz rate to indicate that the time displayed is incorrect.



## HOW TO OBTAIN IMPRESSIONS

Insert the document to be printed between the top and bottom casting. Use the print indicator label to line up desired printing position on document. When the leading edge of the paper engages the trigger the machine will automatically stamp. To get a straight impression, avoid putting the paper into the machine at an angle.

**WARNING:** DO NOT ATTEMPT TO STAMP anything with paper clips, staples, etc. in the area to be printed. This can cause serious damage to the printing wheels and/or die plates.

# RIBBON INSTALLATION

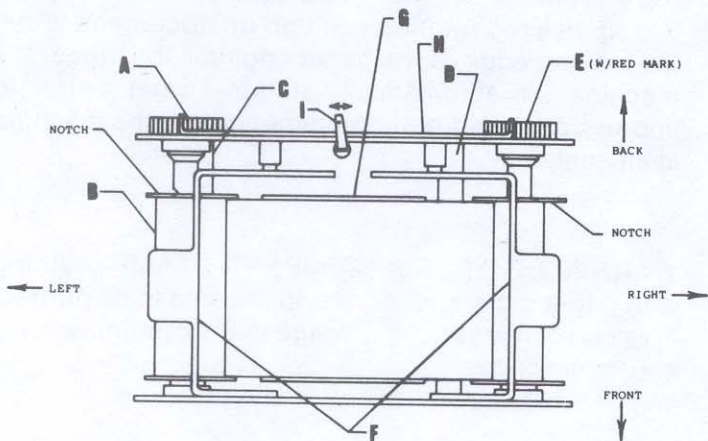

When ordering a new ribbon please refer to the part number 5650 and give the desired color. Purple, green, red, black and blue are available.

## **TO REMOVE OLD RIBBON:**

Unplug machine from outlet, unlock the machine and raise the top casting until it is fully open.

The operator should be facing the front of the machine. Lift ribbon feelers (F) with thumb and forefinger. Using a metal object (e.g. pliers or screwdriver), push in on ribbon shafts from front of machine. Pull ribbon shafts (A) and (E) far enough to remove ribbon. Ribbon shaft (E) has a red mark for identifying right side. Discard old ribbon.

## **TO INSTALL NEW RIBBON:**

Hold ribbon spools so that ribbon unwinds from bottom of spools.

Gently drop ribbon spools onto printing weight (G). Lifting one ribbon feeler (F) at a time, insert ribbon shafts (A) and (E) onto spools by rotating shafts to engage properly. This step assures that ribbon lies *over* frame braces (C) and (D). Push ribbon shafts (A) and (E) back into place.

**CAUTION:** Make sure ribbon feed pawl (H) is lifted out of the way by flipping toggle assembly (I) either to the right or left. Rotate ratchets until all looseness of ribbon is eliminated.

## MAINTENANCE HINTS

Very little maintenance is necessary and, generally speaking, the nature of the machine is such that a qualified serviceman should be called in case the machine fails to operate. However, a few hints are given here.

**BE SURE** that the plug is fully inserted in the wall receptacle.

**LUBRICATE** moving metal parts regularly with a high grade business machine lubricant such as "Molykote G." Use only dry graphite on the printing plunger inside the solenoid coil. Avoid getting oil on the ribbon or any non-metallic or electrical part, and do not lubricate excessively. A drop or two is sufficient.

**Remember** to blow the dust out of your machine occasionally.

**NEVER ATTEMPT** to stamp over metallic objects such as staples and paper clips.

This machine has been preset at the factory. If the application changes contact your dealer.

— NOTES —

— NOTES —





**RAPIDPRINT**